

ULTRA-TECH™ LIGHTING STERILE-BRIGHT™

STRL-TR-250 (300) WUV

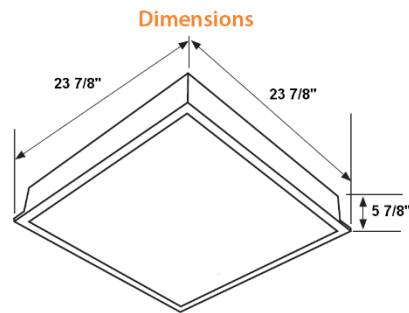

- Sterile-Bright™ LUMENTEC® tuned spectrum
- High energy output
- From 180nm to 457nm
- 100,000 hour life cycle
- 110V~277V and 50hz or 60hz auto-sensing ballast, .98 power factor
- 250-Watt and 300-Watt configurations
- Instant strike/re-strike, no warm-up/cool down
- Nano-particle reflector technology
- VARI-BEAM® focal technology

LIGHTING DISTRIBUTION CURVE

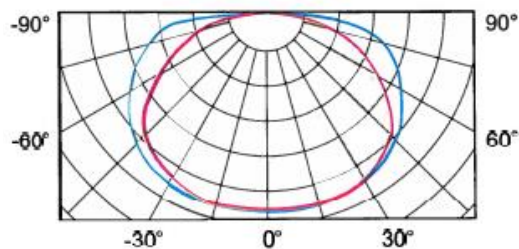

The Sterile-Bright™ 2' x 2' box troffer generates intense sterilizing radiation between **180nm to~456nm**. Ideal for sanitizing hospital rooms including operatories, food service areas, bathrooms, locker rooms, offices, refrigerators, public transportation vehicles (ships, planes, trains), conference rooms, hallways, and common areas. Designed for mounting into hung ceiling grids or direct to ceiling and walls. The unique *exterior bulb design* is capable of evenly dispersing radiation from the source for maximum effectiveness

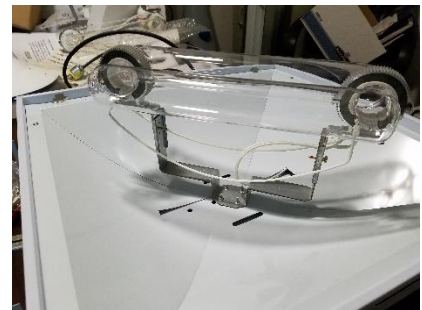

Sterile-Bright™ technology should only be used in *evacuated spaces* free of any people or animals. Ionizing radiation generates ozone that acts as an additional sterilization agent, but is harmful to breath. Special care should be given to insure *safe operation*.

Unlike typical 40-watt fluorescent lamps, a single Sterile-Bright™ troffer generates substantial energy from a 250-watt (or 300-watt) UV generator. This provides maximum efficiency and effectiveness. Mercury is a solid encapsulated amalgam, making Sterile-Bright™ environmentally friendly and safe. No special handling is required. No hazardous material disposal is necessary. See technical specifications on back for more information.

Contact: Philip Gotthelf ♦ (201) 784-1233 x 100 (office) ♦ (201) 401-6068 (cell)
P.O. Box 566, Closter, NJ 07624-0566



TECHNICAL SPECIFICATIONS

MODEL	STRL-TR-250(300)WUV
RATED WATTAGE	250W
VOLTAGE RANGES	110V~277V \pm 15%
CURRENT @ 120V~277V	2.319A @ 110V 250W 2.783A @ 110V 300W 0.92A @ 277V 250W 1.105A @ 277V 300W
FREQUENCY	50/60Hz
POWER FACTOR	0.98
IN-RUSH CURRENT	NEGLIGIBLE
RFI PART 15/18	SHIELDED
NOISE	<20dB
TYPE	MAGNETIC INDUCTION
COLOR RENDITION INDEX	N/A
COLOR TEMPERATURE	180nm~456nm
BALLAST/BULB CERTIFICATIONS	UL-C/CCC/CE/CB/RoHS
TEMPERATURE RANGE	-30°F ~ +140°F
RATING	Indoor Dry
FINISH	Powder Coated
REFLECTOR	FULL-DIFFUSION NANO-PARTICLE
MOUNTING	Grid or Direct mount
LENS	(no lens)
LUMENS PER WATT	N/A
VISUALLY EFFECTIVE LUMENS	N/A

Summary of UV light studies on Coronaviruses

Microbe	D90 dose (exposure) required	Source
Coronavirus	7 J/m ²	Walker 2007
Berne virus (Coronaviridae)	7 J/m ²	Weiss 1986
Murine Coronavirus (MHV)	15 J/m ²	Hirano 1978
Canine Coronavirus (CCV)	29 J/m ²	Saknimit 1988
Murine Coronavirus (MHV)	29 J/m ²	Saknimit 1988
SARS Coronavirus CoV-P9	40 J/m ²	Duan 2003
Murine Coronavirus (MHV)	103 J/m ²	Liu 2003
SARS Coronavirus (Hanoi)	134 J/m ²	Kariwa 2004
SARS Coronavirus (Urbani)	241 J/m ²	Darnell 2004
Coronavirus	7 J/m ²	Walker 2007

